

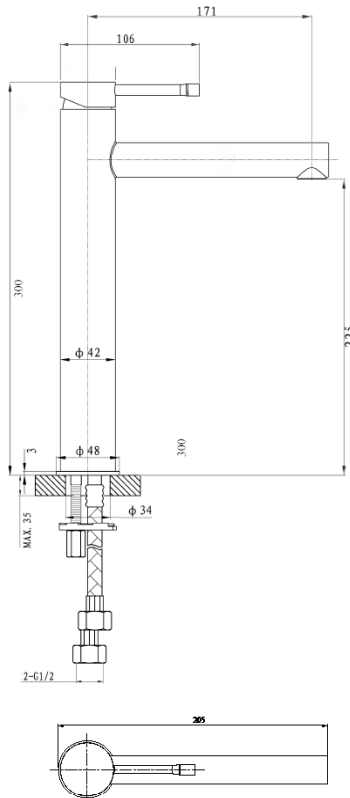

FLOW VESSEL BASIN MIXER

Product Image	Technical Specification
	

Description
<p>Flow Vessel Basin Mixer WELS 5 Star / 6Lpm</p> <p>BM234204 Vessel Basin Mixer - Chrome BM234204MB Vessel Basin Mixer - Matte Black</p>

Additional Information
<ul style="list-style-type: none"> • 35mm European Ceramic Cartridge • Quality PEX Connection Hoses • Superior Flow Regulator • 15 Year Replacement Warranty* <div style="display: flex; justify-content: space-around; align-items: center;">   </div>

