

FISHER & PAYKEL

BLACK GAS COOKTOP

CG301D, CG302D, CG451D, CG603D, CG604D,
CG762D, CG903D& CG905D models

INSTALLATION GUIDE

NZ AU GB IE SEA

⚠ WARNING!



Electric Shock Hazard

Failure to follow this advice may result in electric shock or death.

- Disconnect the appliance from the mains electricity supply before carrying out any work or maintenance.
- Connection to a good earth wiring system is essential and mandatory.
- Alterations to the domestic wiring system must only be made by a qualified electrician.

⚠ WARNING!



Cut Hazard

Failure to use caution could result in injury.

- Take care: some edges are sharp.

READ AND SAVE THIS GUIDE

General Use

- Read these instructions carefully before installing this product.
- Save these instructions for the local electrical inspector's use.
- Installation must comply with your local building and local electricity regulations.
- This appliance is to be installed and serviced only by Fisher & Paykel trained and supported service technician or qualified person.
- The manufacturer accepts no responsibility for the incorrect installation of appliances. Incorrect installation may result in personal injury, damage to property and may invalidate any warranty or liability claims.
- Packing elements (eg plastic bags, polystyrene foam, staples, packing straps etc) and tools should not be left around during and after installation, especially if they are within easy reach of children, as these may cause serious injuries.
- Make sure you recycle the packaging material.
- Before disposing of any appliance, make sure that it can no longer be used and that all hazardous parts are removed or made harmless, so that children playing with the old appliance cannot harm themselves.
- Only genuine replacement parts may be used for servicing the appliance. These are available from your nearest Fisher & Paykel Service Centre.
- These appliances are registered in: New Zealand at www.energysafety.govt.nz and Australia with SAI Global at www.saiglobal.com.
- Appliances are factory set for natural gas but are convertible to ULPG. If in doubt, refer to the local gas network operator or gas supplier to confirm gas type at installation site.
- Do not modify this appliance.
- Do not use or store flammable materials on or near this appliance.
- Do not spray aerosols in the vicinity of this appliance while it is in operation.
- You must remove the transit screws before installing the cooktop.

INITIAL CONSIDERATIONS

PRIOR TO INSTALLATION

Prior to installing your cooktop, ensure:

- the local distribution conditions (nature of gas and pressure) and the adjustment of the appliance are compatible. For adjustment conditions for this appliance see 'Gas rate summary'.
- a suitable disconnection switch is incorporated in the permanent wiring, mounted and positioned to comply with the local wiring rules and regulations. A means of disconnection with at least a 3mm air gap contact separation in all poles must be incorporated into the fixed wiring in accordance with the wiring rules, unless the local wiring rules allow for alternative means.
- the appliance is connected to a 220V - 240V 50Hz (10 A) power supply only and earthed via the power supply cable.
- there is a power outlet within reach of the power supply cable (900mm from the centre rear of the product). This must be accessible after installation. The power supply cable should not touch any metal parts.
- if the power supply cable is damaged, it is replaced only by the special cable: Part no. 534993 KIT SPARES TRMNL BLK-FLEX 10, that can be purchased from authorised Fisher & Paykel Service Agents.
- the supply connection point (gas shut-off valve) is accessible after installation.
- the benchtop is made of a heat-resistant material.
- the installation complies with all the requirements of Australian and New Zealand Gas Installation Standards (AS/NZS 5601.1.2010), including that the product has to be installed so that the surface temperature of any nearby combustible surface will not exceed 65 OC above ambient. Refer to 'Clearance Dimensions'.
- if installed with an approved flexible hose, the hose should not come in contact with the bottom of the appliance or any sharp edges. Flexible hose assemblies should be AS/NZS 1869 Class B or Class D certified with a maximum length of 1.20m.
- seal exposed bare edges of the cutout with an oil-based paint or moisture-proof polyurethane to prevent possible moisture creeping between the cooktop trim and the benchtop.
- take extreme care not to chip, crack, or break the top glass surfaces during installation. A heavy metal tool or part accidentally dropped on the glass could damage it.
- if, after following the instructions given, correct performance cannot be achieved, please contact your nearest Fisher & Paykel Authorised Service Centre, Customer Care, or contact us through our local website listed at the end of this document.

MULTIPLE PRODUCT INSTALLATION

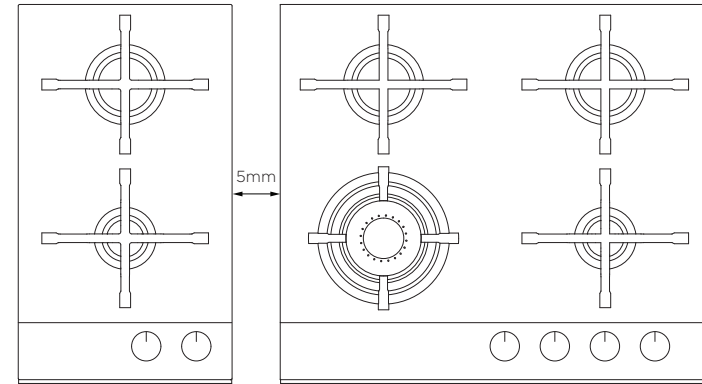

We recommend installing products in separate cutouts with a minimum distance of 5mm between the glass edges. If installing multiple products within the same cutout adjacent to each other, a joining strip kit is required. This kit creates a non non-visual, structural join between the two cooktops that ensures the weight of both cooktops is sufficiently supported. Joining strip kits (PN 534731) can be purchased separately through an authorised Fisher & Paykel dealer. Visit fisherpaykel.com for more information.

The minimum clearance measurements for different products may vary. Always use the greater distance when pairing different products (eg an induction model and wok burner model).

COMPONENTS REQUIRED

PARTS SUPPLIED



Dual wok pan support*

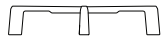

Pan support*



Mini wok pan support*

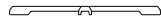

Small pan support*



Wok stand*



Fibre washer



Elbow 1/2" BSP external thread

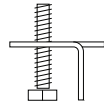

Clamping brackets

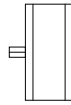

ULPG test point adapter*

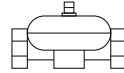

NG regulator*

TOOLS REQUIRED

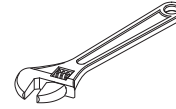

Wrench

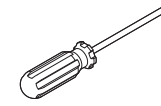

Crosshead screwdriver



Silicone

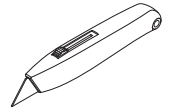

Cutter



Hex key

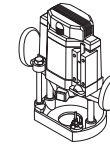

Router

PRODUCT DIMENSIONS – 300MM MODELS

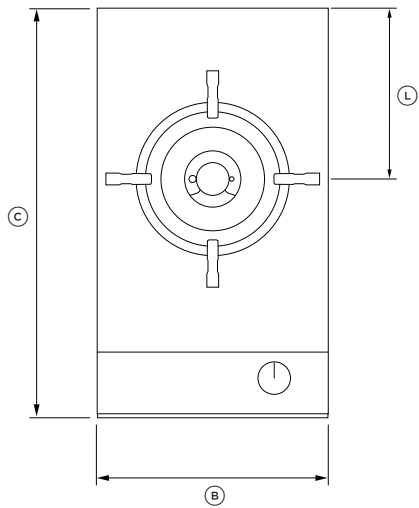

PLAN

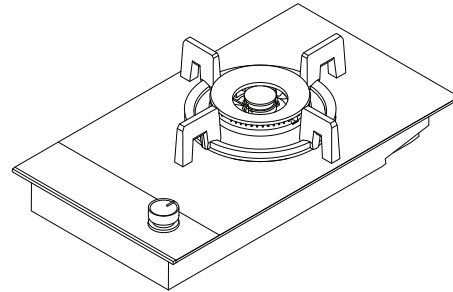

ISOMETRIC

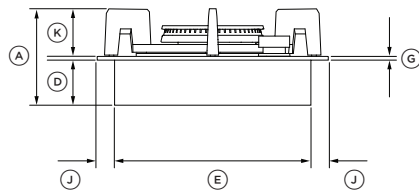

FRONT

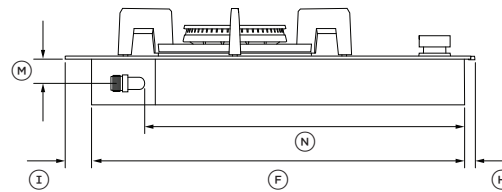

PROFILE

PRODUCT DIMENSIONS	CG301	CG302
	MM	MM
Ⓐ Overall height of cooktop*	124	108
Ⓑ Overall width of cooktop	299	299
Ⓒ Overall depth of cooktop	530	530
Ⓓ Height of chassis	59	59
Ⓔ Width of chassis	254	254
Ⓕ Depth of chassis	485	485
Ⓖ Height of cooktop glass and flange	5	5
Ⓗ Depth of front overhang of cooktop glass	11	11
Ⓘ Depth of rear overhang of cooktop glass**	34	34
Ⓙ Depth of side overhang of cooktop glass**	22	22
Ⓚ Height of tallest trivet***	61	45
Ⓛ Distance from centre of rear burner to rear of cooktop	219	112
Ⓜ Height from benchtop to centre of gas inlet*	32	32
Ⓝ Depth from front of chassis to gas inlet*	465	465

Note: CG301 illustrated. Profile view showing left side of cooktop.

* Including tallest trivet

** Including flange

*** From cooktop surface

PRODUCT DIMENSIONS – 450MM MODELS

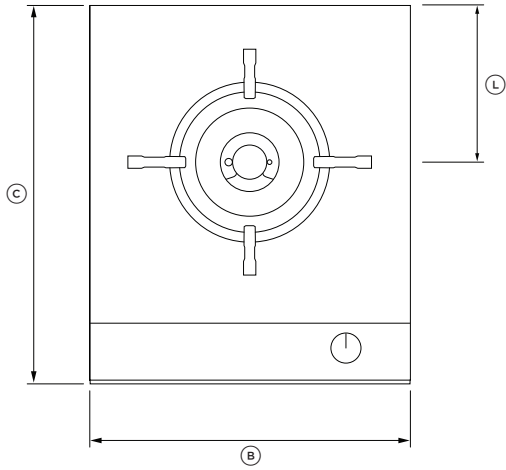

PLAN

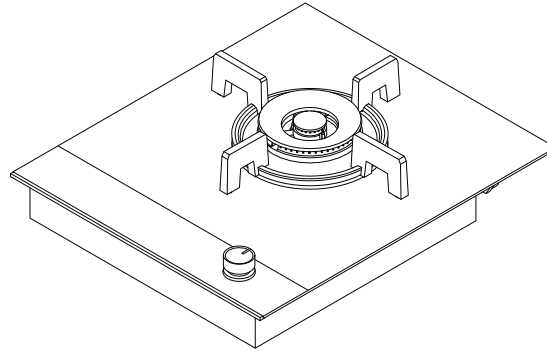

ISOMETRIC

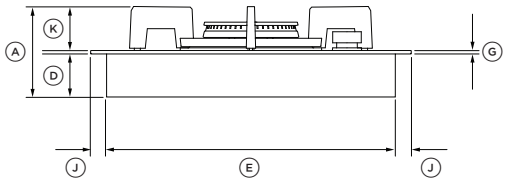

FRONT

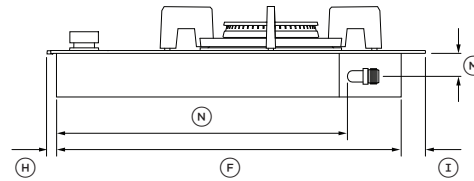

PROFILE

PRODUCT DIMENSIONS	CG451
	MM
Ⓐ Overall height of cooktop*	124
Ⓑ Overall width of cooktop	449
Ⓒ Overall depth of cooktop	530
Ⓓ Height of chassis	58
Ⓔ Width of chassis	404
Ⓕ Depth of chassis	485
Ⓖ Height of cooktop glass and flange	5
Ⓗ Depth of front overhang of cooktop glass	11
Ⓘ Depth of rear overhang of cooktop glass**	34
Ⓝ Depth of side overhang of cooktop glass**	22
Ⓚ Height of tallest trivet***	61
Ⓛ Distance from centre of rear burner to rear of cooktop	216
Ⓜ Height from benchtop to centre of gas inlet*	32
Ⓝ Depth from front of chassis to gas inlet*	483

* Including tallest trivet

** Including flange

*** From cooktop surface

PRODUCT DIMENSIONS – 600MM MODELS

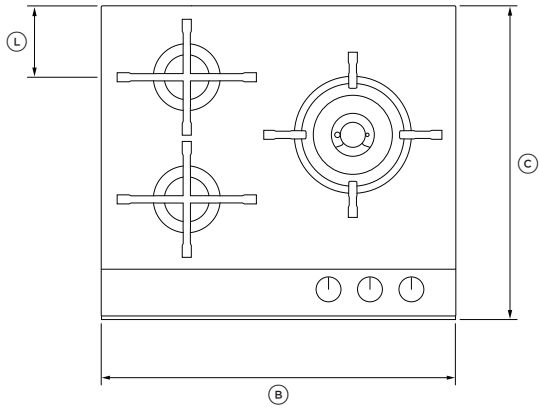

PLAN

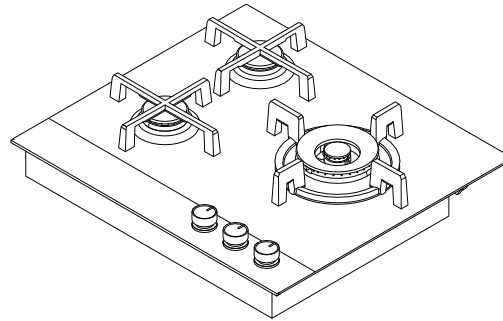

ISOMETRIC

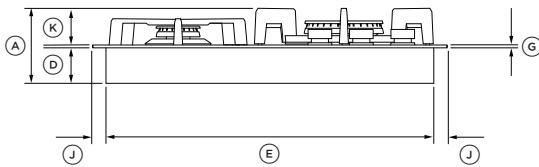

FRONT

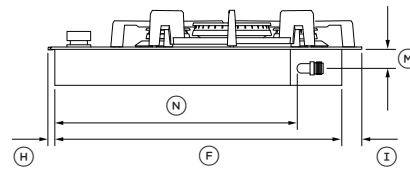

PROFILE

PRODUCT DIMENSIONS	CG603D	CG604D
	MM	MM
(A) Overall height of cooktop*	124	116
(B) Overall width of cooktop	599	599
(C) Overall depth of cooktop	530	530
(D) Height of chassis	58	58
(E) Width of chassis	554	554
(F) Depth of chassis	485	485
(G) Height of cooktop glass and flange	5	5
(H) Depth of front overhang of cooktop glass	11	11
(I) Depth of rear overhang of cooktop glass**	34	34
(J) Depth of side overhang of cooktop glass**	23	23
(K) Height of tallest trivet***	61	53
(L) Distance from centre of rear burner to rear of cooktop	112	112
(M) Height from benchtop to centre of gas inlet*	32	32
(N) Depth from front of chassis to gas inlet*	409	409

Note: CG603 illustrated.

* Including tallest trivet

** Including flange

***From cooktop surface

PRODUCT DIMENSIONS – 760MM MODELS

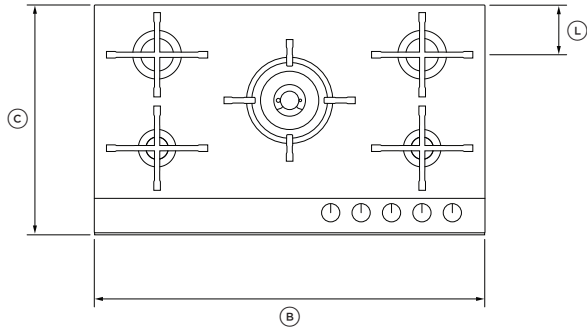

PLAN

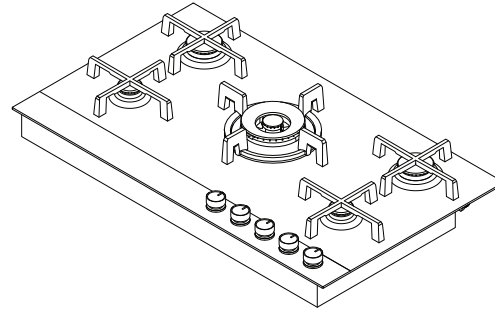

ISOMETRIC

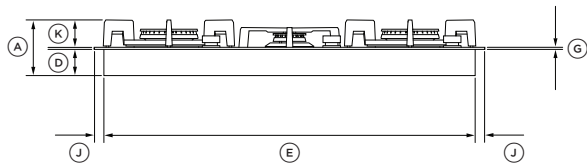

FRONT

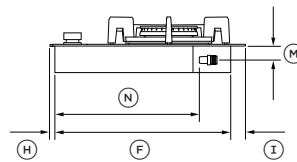

PROFILE

PRODUCT DIMENSIONS

CG762D

MM

Ⓐ	Overall height of cooktop*	124
Ⓑ	Overall width of cooktop	759
Ⓒ	Overall depth of cooktop	450
Ⓓ	Height of chassis	58
Ⓔ	Width of chassis	704
Ⓕ	Depth of chassis	405
Ⓖ	Height of cooktop glass and flange	5
Ⓗ	Depth of front overhang of cooktop glass	11
Ⓘ	Depth of rear overhang of cooktop glass**	34
Ⓝ	Depth of side overhang of cooktop glass**	22
Ⓚ	Height of tallest trivet***	61
Ⓛ	Distance from centre of rear burner to rear of cooktop	176
Ⓜ	Height from benchtop to centre of gas inlet	32
Ⓝ	Depth from front of chassis to gas inlet*	329

* Including tallest trivet

** Including flange

*** From cooktop surface

PRODUCT DIMENSIONS – 900MM MODELS

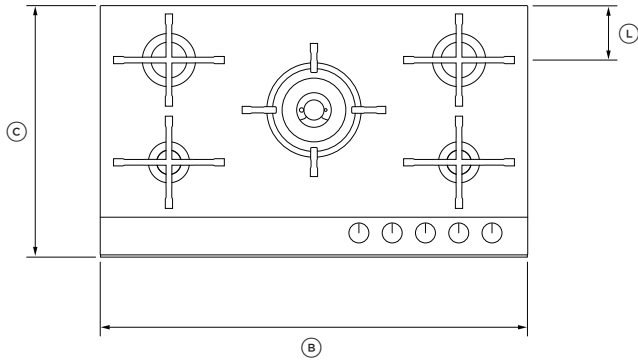

PLAN

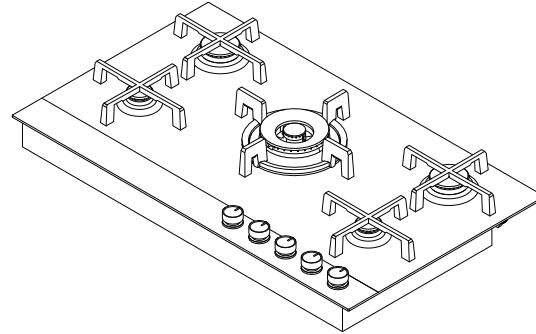

ISOMETRIC

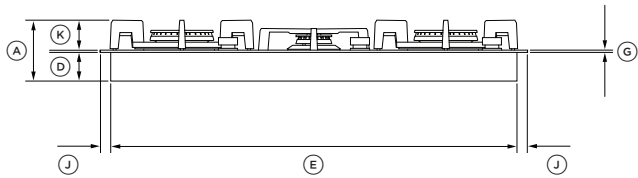

FRONT

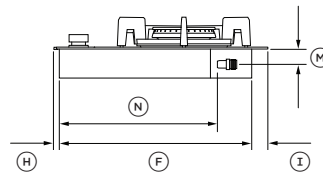

PROFILE

PRODUCT DIMENSIONS	CG903D	CG905D
	MM	MM
Ⓐ Overall height of cooktop*	124	124
Ⓑ Overall width of cooktop	899	899
Ⓒ Overall depth of cooktop	450	530
Ⓓ Height of chassis	58	58
Ⓔ Width of chassis	854	854
Ⓕ Depth of chassis	405	485
Ⓖ Height of cooktop glass and flange	5	5
Ⓗ Depth of front overhang of cooktop glass	11	11
Ⓘ Depth of rear overhang of cooktop glass**	34	34
Ⓙ Depth of side overhang of cooktop glass**	22	22
Ⓚ Height of tallest trivet***	61	61
Ⓛ Distance from centre of rear burner to rear of cooktop	176	112
Ⓜ Height from benchtop to centre of gas inlet*	30	30
Ⓝ Depth from front of chassis to gas inlet*	332	332

Note: CG905 illustrated.
 * Including tallest trivet
 ** Including flange
 *** From cooktop surface

CUTOUT DIMENSIONS — 300MM MODELS

PROUD INSTALLATION

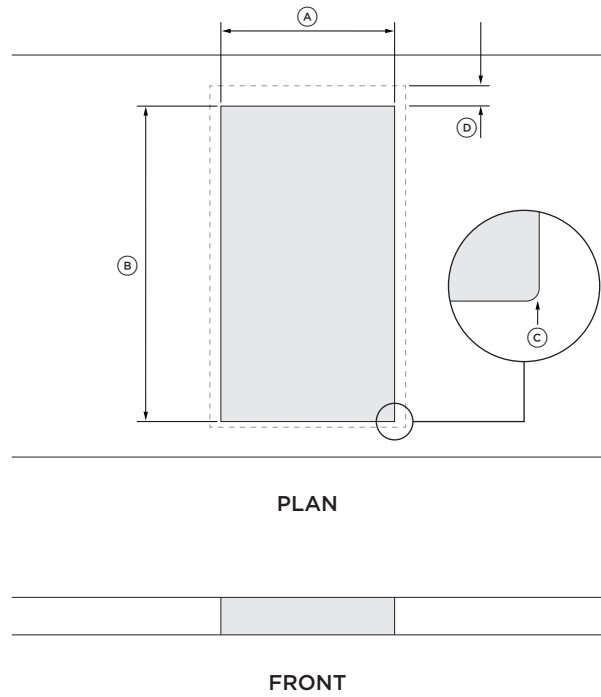

CUTOUT DIMENSIONS	CG301D	CG302D
	MM	MM
Ⓐ Overall width of cutout	260	260
Ⓑ Overall depth of cutout	490	490
Ⓒ Corner radius of cutout	max 10	max 10
Ⓓ Offset overhang allowance	39	39

FLUSH INSTALLATION

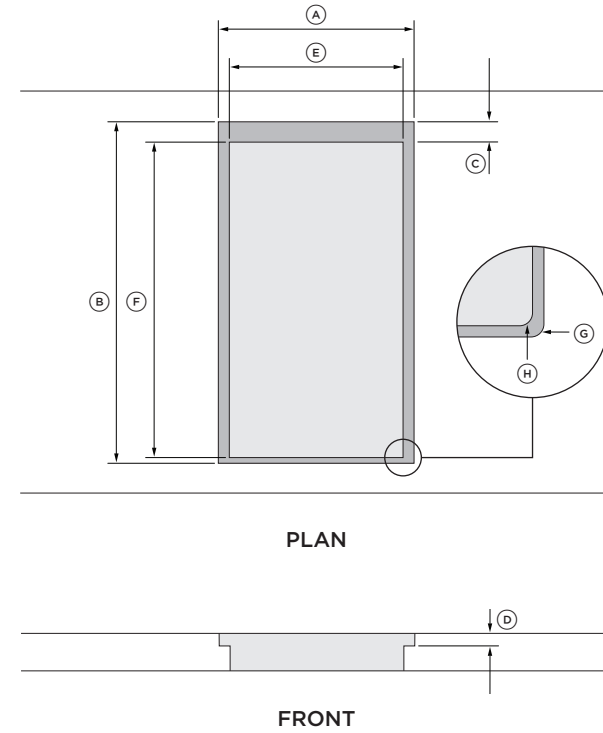

CUTOUT DIMENSIONS	CG301D	CG302D
	MM	MM
Ⓐ Overall width of routed recess	305	305
Ⓑ Overall depth of routed recess	535	535
Ⓒ Offset overhang allowance	39	39
Ⓓ Height of routed recess	5	5
Ⓔ Width of cutout	260	260
Ⓕ Depth of cutout	490	490
Ⓖ Corner radius of routed recess	max 2	max 2
Ⓗ Corner radius of cutout	max 10	max 10

CUTOUT DIMENSIONS – 450MM MODELS

PROUD INSTALLATION

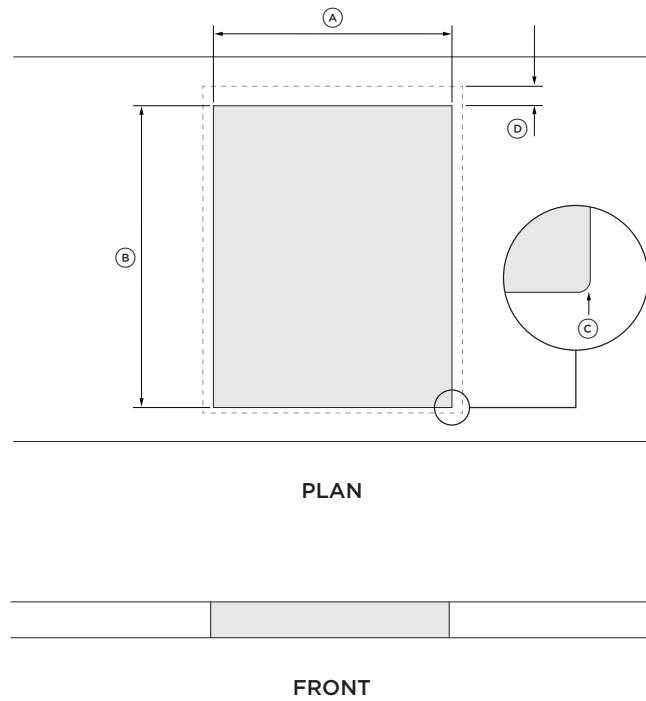

CUTOUT DIMENSIONS	CG451D MM
Ⓐ Overall width of cutout	415
Ⓑ Overall depth of cutout	490
Ⓒ Corner radius of cutout	max 10
Ⓓ Offset overhang allowance	39

FLUSH INSTALLATION

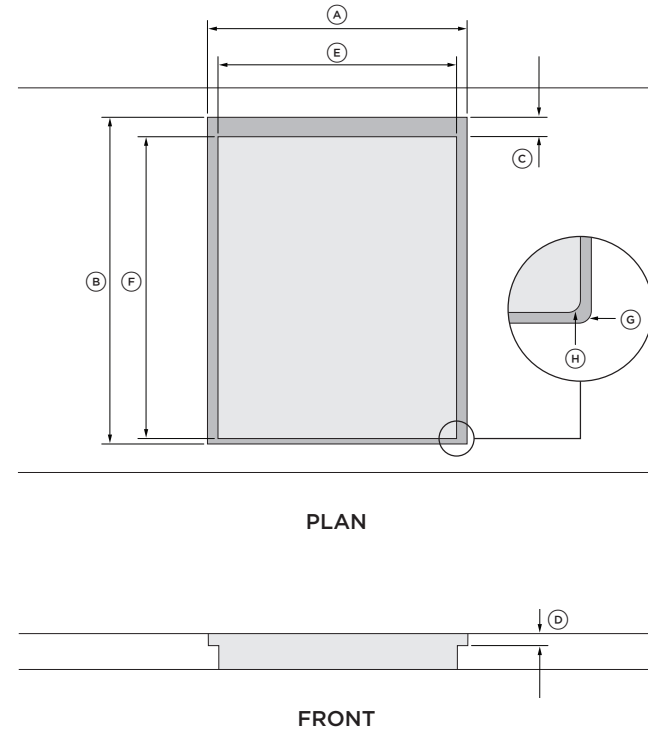

CUTOUT DIMENSIONS	CG451D MM
Ⓐ Overall width of routed recess	455
Ⓑ Overall depth of routed recess	535
Ⓒ Offset overhang allowance	39
Ⓓ Height of routed recess	5
Ⓔ Width of cutout	415
Ⓕ Depth of cutout	490
Ⓖ Corner radius of routed recess	max 2
Ⓗ Corner radius of cutout	max 10

CUTOUT DIMENSIONS – 600MM MODELS

PROUD INSTALLATION

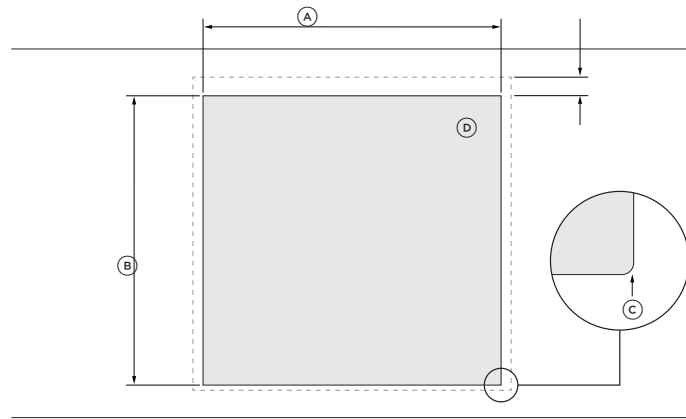

PLAN



FRONT

CUTOUT DIMENSIONS	CG603D	CG604D
	MM	MM
Ⓐ Overall width of cutout	560	560
Ⓑ Overall depth of cutout	490	490
Ⓒ Corner radius of cutout	max 10	max 10
Ⓓ Offset overhang allowance	39	39

FLUSH INSTALLATION

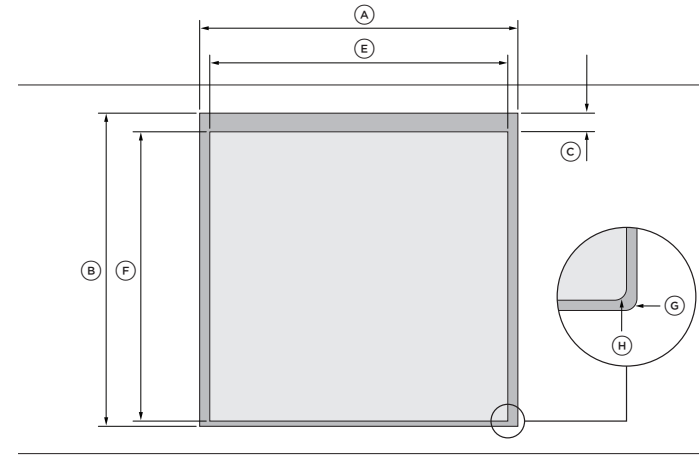

PLAN

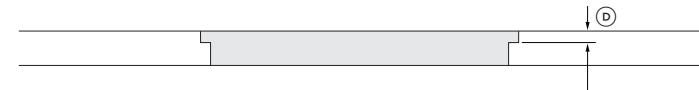

FRONT

CUTOUT DIMENSIONS	CG603D	CG604D
	MM	MM
Ⓐ Overall width of routed recess	605	605
Ⓑ Overall depth of routed recess	535	535
Ⓒ Offset overhang allowance	39	39
Ⓓ Height of routed recess	5	5
Ⓔ Width of cutout	560	560
Ⓕ Depth of cutout	490	490
Ⓖ Corner radius of routed recess	max 2	max 2
Ⓗ Corner radius of cutout	max 10	max 10

CUTOUT DIMENSIONS – 760MM MODELS

PROUD INSTALLATION

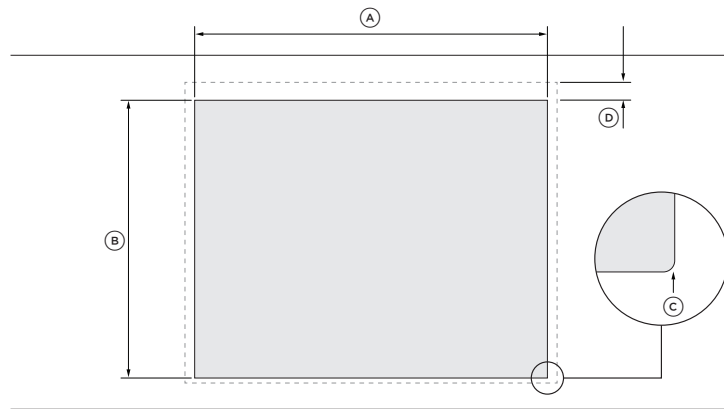

PLAN



FRONT

CUTOUT DIMENSIONS	CG762D
	MM
Ⓐ Overall width of cutout	715
Ⓑ Overall depth of cutout	410
Ⓒ Corner radius of cutout	max 10
Ⓓ Offset overhang allowance	39

FLUSH INSTALLATION

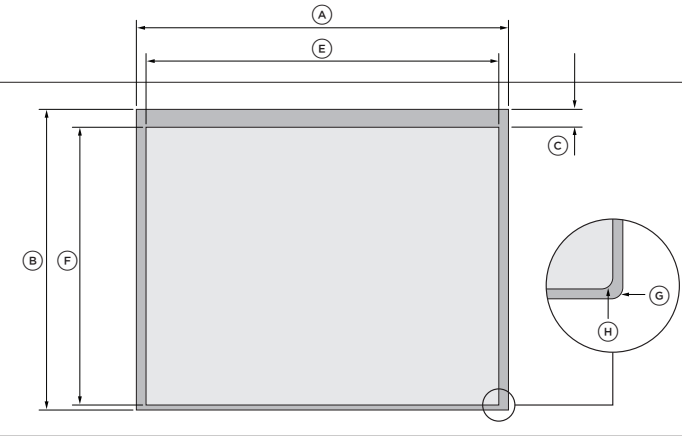

PLAN

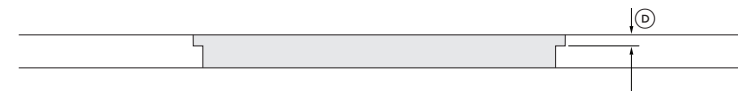

FRONT

CUTOUT DIMENSIONS	CG762D
	MM
Ⓐ Overall width of routed recess	765
Ⓑ Overall depth of routed recess	455
Ⓒ Offset overhang allowance	39
Ⓓ Height of routed recess	5
Ⓔ Width of cutout	715
Ⓕ Depth of cutout	410
Ⓖ Corner radius of routed recess	max 2
Ⓗ Corner radius of cutout	max 10

CUTOUT DIMENSIONS – 900MM MODELS

PROUD INSTALLATION

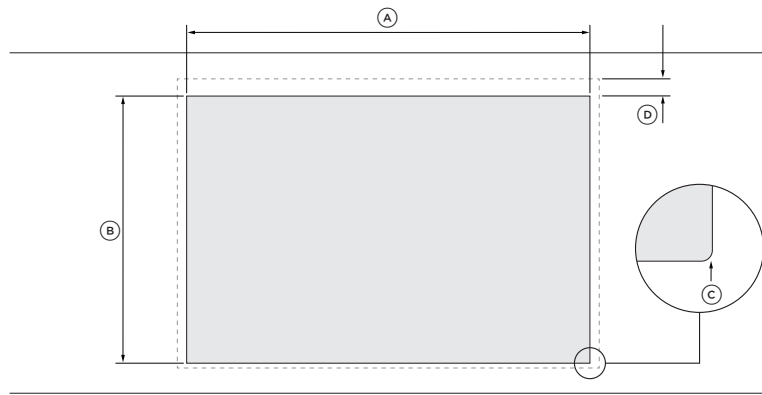

PLAN



FRONT

CUTOUT DIMENSIONS	CG903D	CG905D
	MM	MM
Ⓐ Overall width of cutout	865	865
Ⓑ Overall depth of cutout	410	490
Ⓒ Corner radius of cutout	max 10	max 10
Ⓓ Offset overhang allowance	39	39

FLUSH INSTALLATION

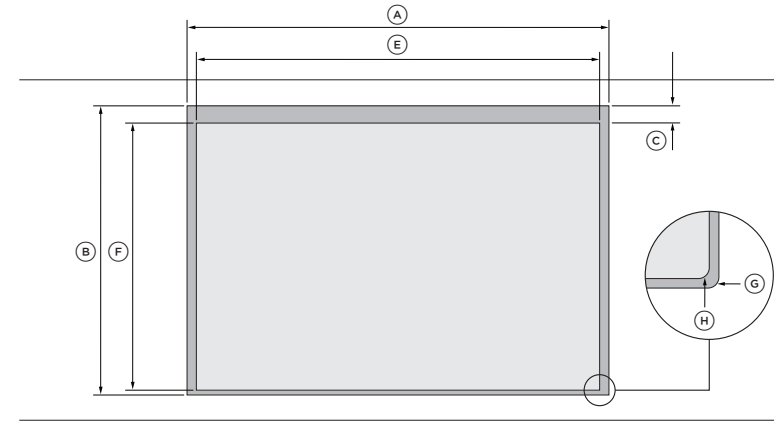

PLAN



FRONT

CUTOUT DIMENSIONS	CG903D	CG905D
	MM	MM
Ⓐ Overall width of routed recess	905	905
Ⓑ Overall depth of routed recess	455	535
Ⓒ Offset overhang allowance	39	39
Ⓓ Height of routed recess	5	5
Ⓔ Width of cutout	865	865
Ⓕ Depth of cutout	410	490
Ⓖ Corner radius of routed recess	max 2	max 2
Ⓗ Corner radius of cutout	max 10	max 10

CLEARANCES — 300MM MODELS

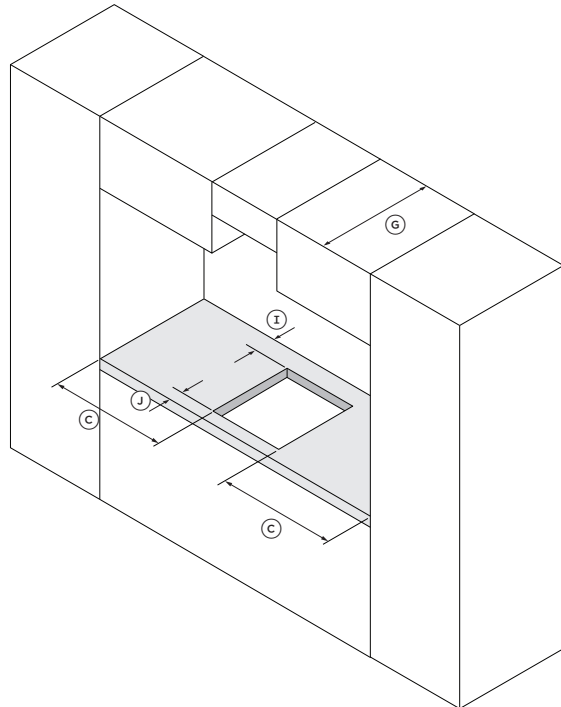
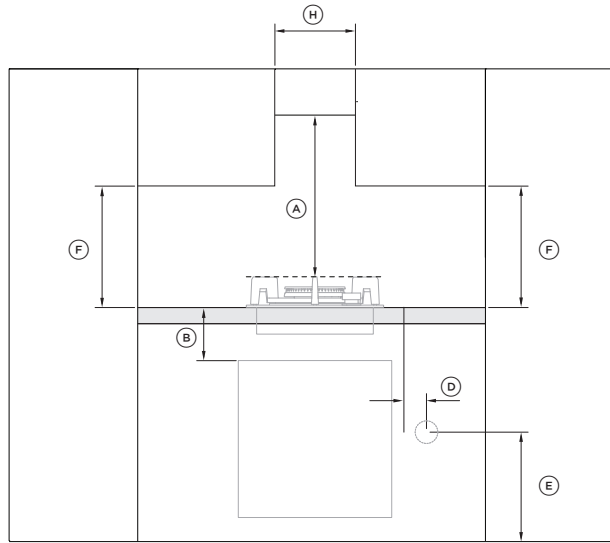

CLEARANCE DIMENSIONS	CG301D	CG302D
	MM	MM
(A) Minimum clearance from top of trivets to:		
• Rangehood	650	650
• Overhead exhaust fan	800	800
• Downward facing combustibile surface*	650	650
• Downwards-facing tiled or fire resistant surface	500	500
(B) Minimum clearance below bench top to:		
• Combustibile surface	70	70
• Fisher & Paykel oven or nearest non-combustibile surface	65	65
(C) Minimum clearance from cutout to nearest combustibile surface	120	120
(D) Minimum distance from right edge of cooktop to gas connection point on wall (if using a flexible hose)	250	250
(E) Distance from floor to gas connection point on wall (if using a flexible hose)	800-850	800-850
(F) Minimum clearance from countertop to overhead cabinet (not directly above the cooktop)	450	450
(G) Maximum depth of overhead cabinetry	600	600
(H) Minimum distance between overhead cabinets (either side of the cooktop)	315	315
(I) Minimum clearance from rear edge of cutout to nearest:		
• Combustibile surface	160	160
• Non-combustibile surface	45	45
(J) Minimum clearance from front edge of cutout to counter front	35	35

Ensure there is an earthed power outlet within 900mm of the centre rear of the product. The gas connector on the wall should be accessible with the product installed.

*Combustibile surface definition

Any materials of a building structure or decorative structure made of wood, compressed paper, plant fibres, vinyl/plastic or other materials that are capable of transferring heat or being ignited and burned. Such material shall be considered combustibile even though flame-proofed, fire-retardant treated or surface-painted, or plastered.

CLEARANCES – 450MM MODELS

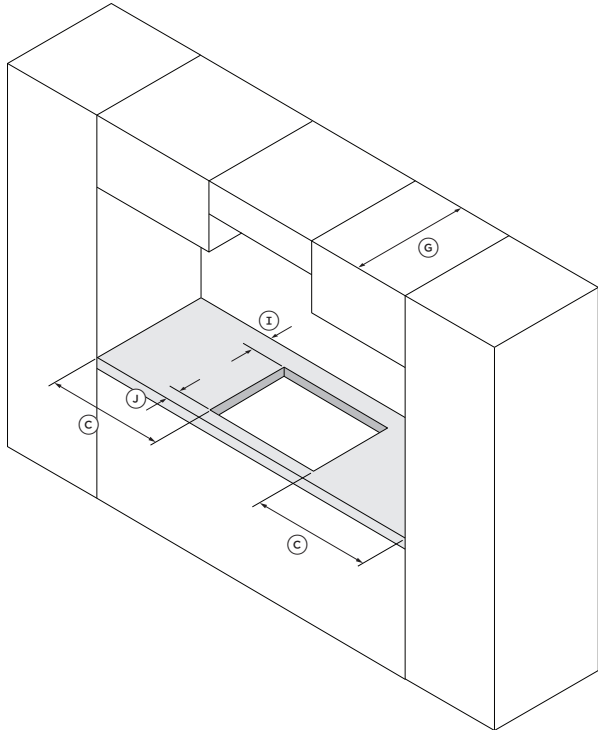
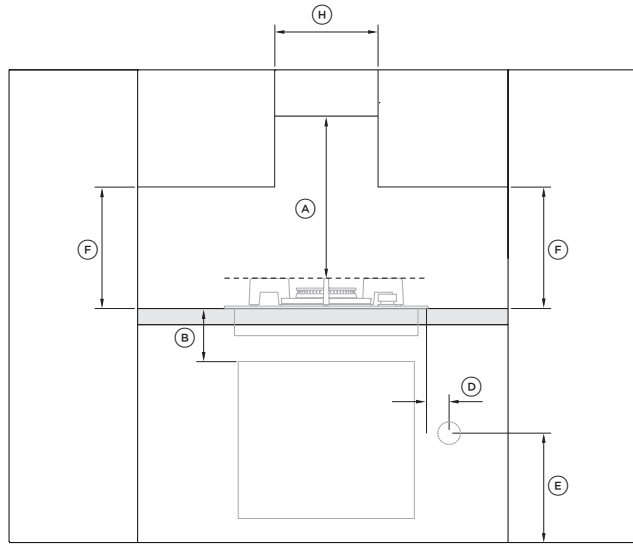

CLEARANCE DIMENSIONS		CG451D
		MM
(A)	Minimum clearance from top of trivets to:	
	• Rangehood	650
	• Overhead exhaust fan	800
	• Downward facing combustibile surface*	650
	• Downwards-facing tiled or fire resistant surface	500
(B)	Minimum clearance below bench top to:	
	• Combustibile surface	70
	• Fisher & Paykel oven or nearest non-combustibile surface	65
(C)	Minimum clearance from cutout to nearest combustibile surface	60
(D)	Minimum distance from right edge of cooktop to gas connection point on wall (if using a flexible hose)	250
(E)	Distance from floor to gas connection point on wall (if using a flexible hose)	800-850
(F)	Minimum clearance from countertop to overhead cabinet (not directly above the cooktop)	450
(G)	Maximum depth of overhead cabinetry	600
(H)	Minimum distance between overhead cabinets (either side of the cooktop)	315
(I)	Minimum clearance from rear edge of cutout to nearest:	85
	• Combustibile surface	85
	• Non-combustibile surface	45
(J)	Minimum clearance from front edge of cutout to counter front	35

Ensure there is an earthed power outlet within 900mm of the centre rear of the product. The gas connector on the wall should be accessible with the product installed.

*Combustibile surface definition

Any materials of a building structure or decorative structure made of wood, compressed paper, plant fibres, vinyl/plastic or other materials that are capable of transferring heat or being ignited and burned. Such material shall be considered combustibile even though flame-proofed, fire-retardant treated or surface-painted, or plastered.

CLEARANCES — 600MM MODELS

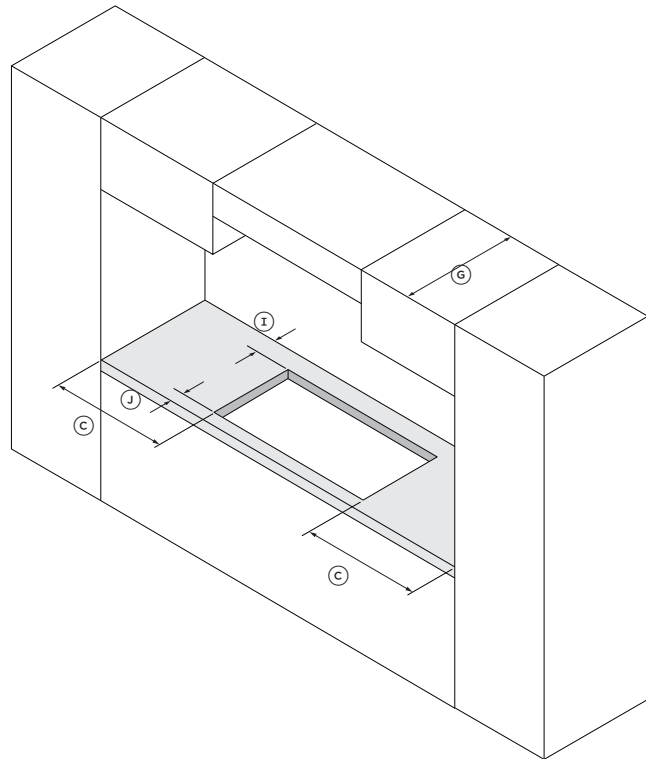
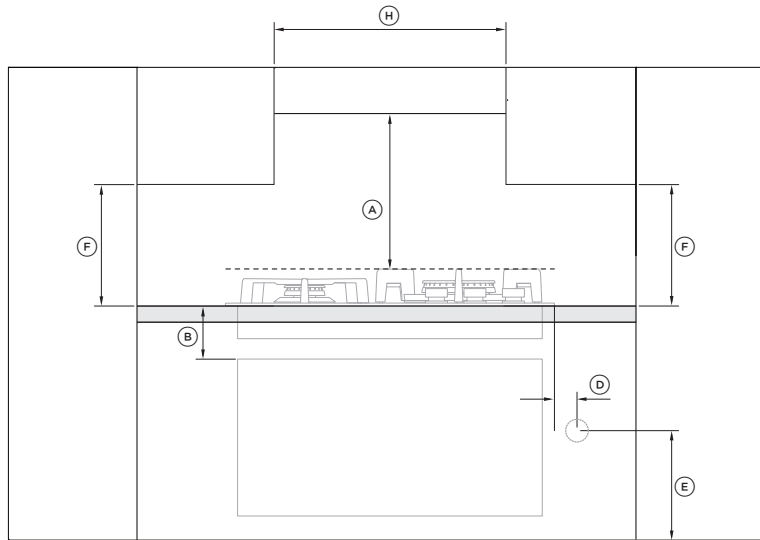

CLEARANCE DIMENSIONS	CG603D	CG604D
	MM	MM
(A) Minimum clearance from top of trivets to:		
• Rangehood	650	650
• Overhead exhaust fan	800	800
• Downward facing combustibile surface*	650	650
• Downwards-facing tiled or fire resistant surface	500	500
(B) Minimum clearance below bench top to:		
• Combustibile surface	70	70
• Fisher & Paykel oven or nearest non-combustibile surface	65	65
(C) Minimum clearance from cutout to nearest combustibile surface	115	130
(D) Minimum distance from right edge of cooktop to gas connection point on wall (if using a flexible hose)	250	250
(E) Distance from floor to gas connection point on wall (if using a flexible hose)	800-850	800-850
(F) Minimum clearance from countertop to overhead cabinet (not directly above the cooktop)	450	450
(G) Maximum depth of overhead cabinetry	600	600
(H) Minimum distance between overhead cabinets (either side of the cooktop)	315	315
(I) Minimum clearance from rear edge of cutout to nearest:		
• Combustibile surface	160	160
• Non-combustibile surface	45	
(J) Minimum clearance from front edge of cutout to counter front	35	35

Ensure there is an earthed power outlet within 900mm of the centre rear of the product. The gas connector on the wall should be accessible with the product installed.

*Combustibile surface definition

Any materials of a building structure or decorative structure made of wood, compressed paper, plant fibres, vinyl/plastic or other materials that are capable of transferring heat or being ignited and burned. Such material shall be considered combustibile even though flame-proofed, fire-retardant treated or surface-painted, or plastered.

CLEARANCES – 750MM MODELS

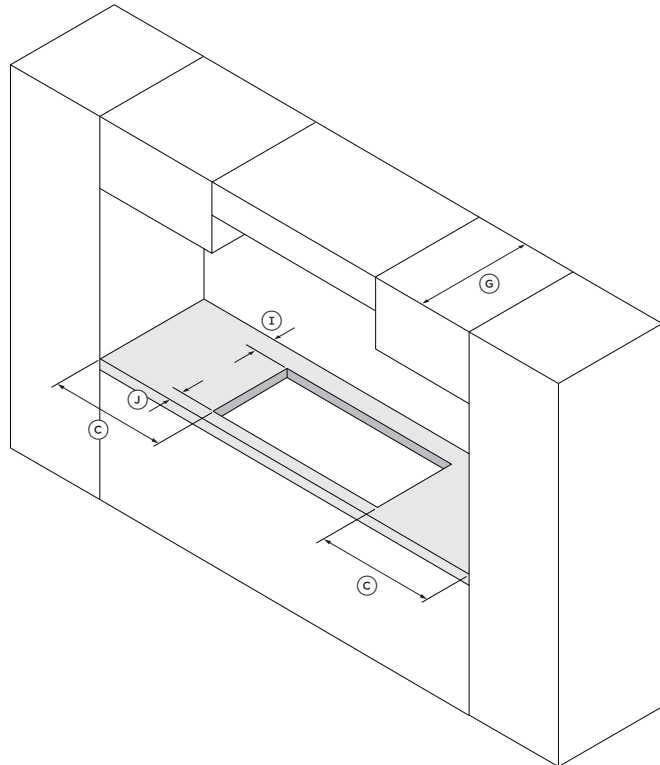
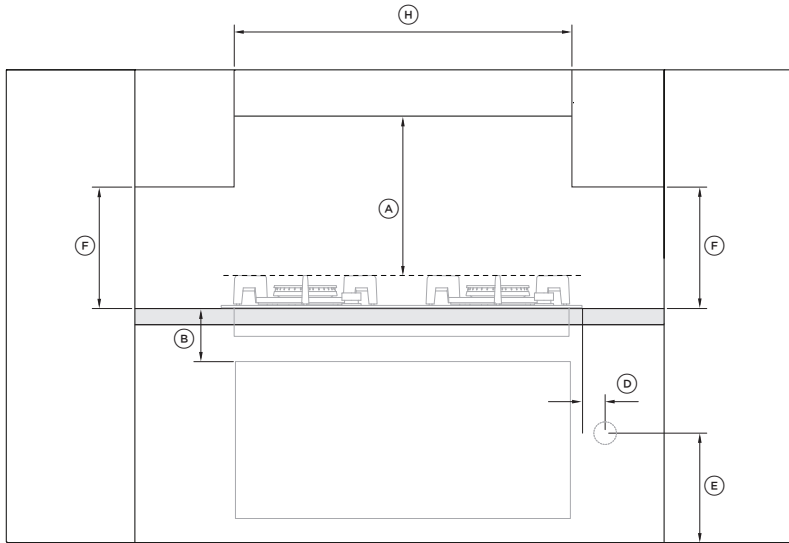

CLEARANCE DIMENSIONS		CG762D
		MM
Ⓐ	Minimum clearance from top of trivets to:	
	• Rangehood	650
	• Overhead exhaust fan	800
	• Downward facing combustibile surface*	650
Ⓑ	Minimum clearance below bench top to:	
	• Fisher & Paykel oven or nearest non-combustibile surface	65
Ⓒ	Minimum clearance from cutout to nearest combustibile surface	115
Ⓓ	Minimum distance from right edge of cooktop to gas connection point on wall (if using a flexible hose)	250
Ⓔ	Distance from floor to gas connection point on wall (if using a flexible hose)	800-850
Ⓕ	Minimum clearance from countertop to overhead cabinet (not directly above the cooktop)	450
Ⓖ	Maximum depth of overhead cabinetry	600
Ⓗ	Minimum distance between overhead cabinets (either side of the cooktop)	315
Ⓘ	Minimum clearance from rear edge of cutout to nearest:	
	• Non-combustibile surface	45
⓵	Minimum clearance from front edge of cutout to counter front	35

Ensure there is an earthed power outlet within 900mm of the centre rear of the product. The gas connector on the wall should be accessible with the product installed.

*Combustibile surface definition

Any materials of a building structure or decorative structure made of wood, compressed paper, plant fibres, vinyl/plastic or other materials that are capable of transferring heat or being ignited and burned. Such material shall be considered combustibile even though flame-proofed, fire-retardant treated or surface-painted, or plastered.

CLEARANCES — 900MM MODELS

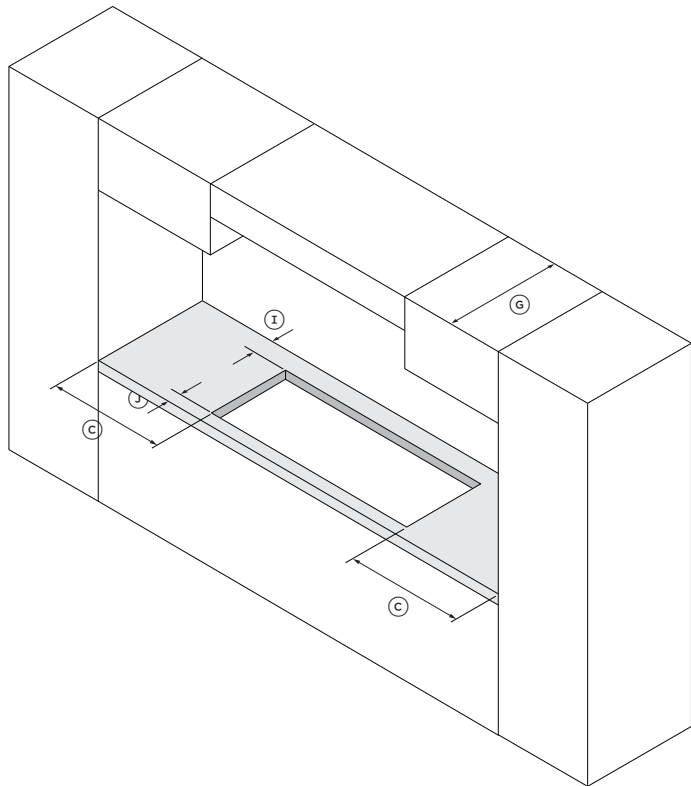
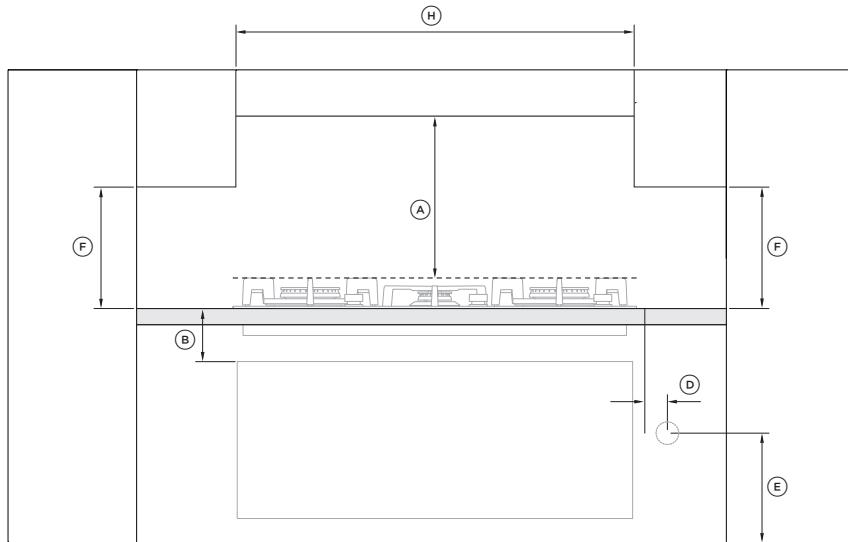

CLEARANCE DIMENSIONS	CG903D	CG905D
	MM	MM
(A) Minimum clearance from top of trivets to:		
• Rangehood	650	650
• Overhead exhaust fan	800	800
• Downward facing combustable surface*	650	650
• Downwards-facing tiled or fire resistant surface	500	500
(B) Minimum clearance below bench top to:		
• Combustable surface	70	70
• Fisher & Paykel oven or nearest non-combustible surface	65	65
(C) Minimum clearance from cutout to nearest combustable surface	115	130
(D) Minimum distance from right edge of cooktop to gas connection point on wall (if using a flexible hose)	250	250
(E) Distance from floor to gas connection point on wall (if using a flexible hose)	800-850	800-850
(F) Minimum clearance from countertop to overhead cabinet (not directly above the cooktop)	450	450
(G) Maximum depth of overhead cabinetry	600	600
(H) Minimum distance between overhead cabinets (either side of the cooktop)	315	315
(I) Minimum clearance from rear edge of cutout to nearest:		
• Combustable surface	125	160
• Non-combustible surface	45	45
(J) Minimum clearance from front edge of cutout to counter front	35	35

Ensure there is an earthed power outlet within 900mm of the centre rear of the product. The gas connector on the wall should be accessible with the product installed.

*Combustible surface definition

Any materials of a building structure or decorative structure made of wood, compressed paper, plant fibres, vinyl/plastic or other materials that are capable of transferring heat or being ignited and burned. Such material shall be considered combustable even though flame-proofed, fire-retardant treated or surface-painted, or plastered.

GAS RATE SUMMARY

CG301D MODELS

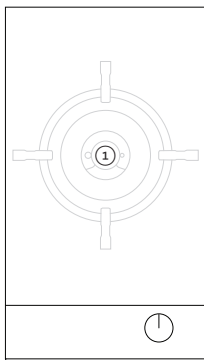

BURNER	GAS TYPE	JET SIZE (MM)	NOMINAL RATING (MJ/H)
① Dual wok	NG (1.00kPa)*	1.45	21.50
		1.45	
		0.70	
		1.45	
	ULPG (2.75kPa)*	1.45	21.50
		0.70	

*Nominal pressure with at least one large burner on high

CG302D MODELS

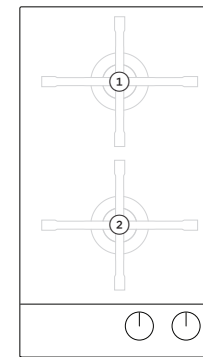

BURNER	GAS TYPE	JET SIZE (MM)	NOMINAL RATING (MJ/H)
① Semi-rapid	NG (1.00kPa)*	1.35	8.80
	ULPG (2.75kPa)*	0.80	8.10
② Auxiliary	NG (1.00kPa)*	1.00	5.00
	ULPG (2.75kPa)*	0.64	5.00

*Nominal pressure with at least one large burner on high

All appliances are factory set for either Natural Gas or ULPG and are not convertible. Check the 'Gas type' sticker on the base of the appliance.

GAS RATE SUMMARY

CG451D MODELS

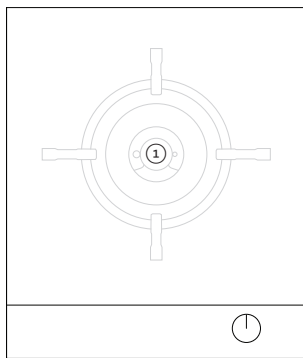

BURNER	GAS TYPE	JET SIZE (MM)	NOMINAL RATING (MJ/H)
① Dual wok	NG (1.00kPa)*	1.43	21.0
		1.43	
		0.70	
	ULPG (2.75kPa)*	0.80	20.50
		0.50	

*Nominal pressure with at least one large burner on high

CG603D MODELS

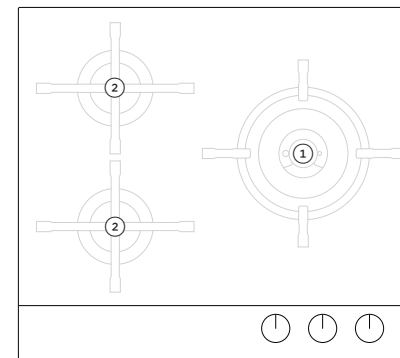

BURNER	GAS TYPE	JET SIZE (MM)	NOMINAL RATING (MJ/H)
① Dual wok	NG (1.00kPa)*	1.26	16.60
		1.26	
		0.70	
	ULPG (2.75kPa)*	0.73	16.80
		0.50	
② Semi-rapid	NG (1.00kPa)*	1.30	8.40
	ULPG (2.75kPa)*	0.76	7.50

*Nominal pressure with at least one large burner on high

GAS RATE SUMMARY

CG604D MODELS

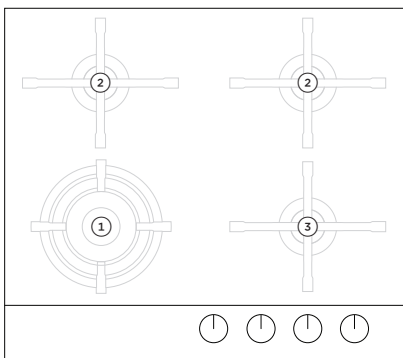

BURNER	GAS TYPE	JET SIZE (MM)	NOMINAL RATING (MJ/H)
① Mini wok	NG (1.00kPa)*	1.55	11.70
	ULPG (2.75kPa)*	0.94	11.70
② Semi-rapid	NG (1.00kPa)*	1.30	8.30
	ULPG (2.75kPa)*	0.76	7.50
③ Auxiliary	NG (1.00kPa)*	0.85	3.60
	ULPG (2.75kPa)*	0.55	3.60

*Nominal pressure with at least one large burner on high

CG762D MODELS

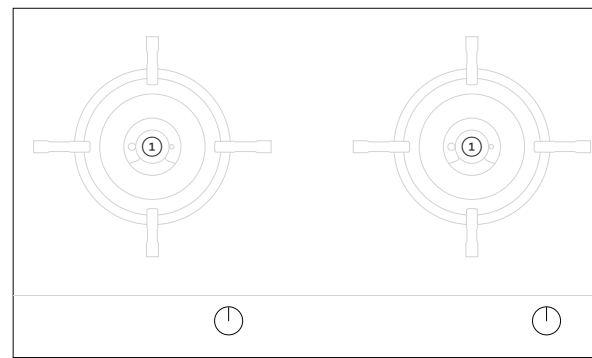

BURNER	GAS TYPE	JET SIZE (MM)	NOMINAL RATING (MJ/H)
① Dual wok	NG (1.00kPa)*	1.30	18.00
		0.70	
		0.76	
① Dual wok	ULPG (2.75kPa)*	0.76	18.00
		0.50	

*Nominal pressure with at least one large burner on high

GAS RATE SUMMARY

CG903D MODELS

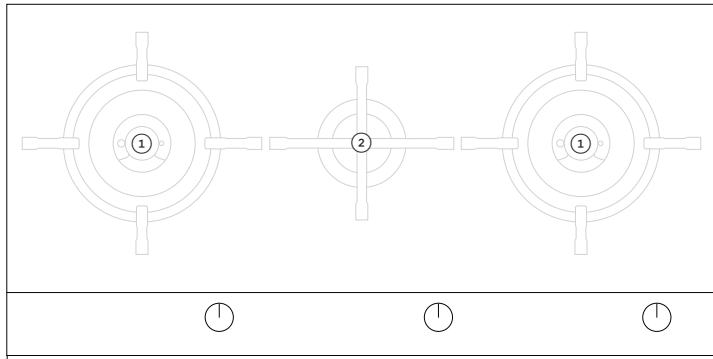

BURNER	GAS TYPE	JET SIZE (MM)	NOMINAL RATING (MJ/H)
① Dual wok	NG (1.00kPa)*	1.30	18.00
		0.70	
	ULPG (2.75kPa)*	0.76	18.00
		0.50	
② Semi-rapid	NG (1.00kPa)*	1.30	8.30
	ULPG (2.75kPa)*	0.76	7.50

*Nominal pressure with at least one large burner on high

CG905D MODELS

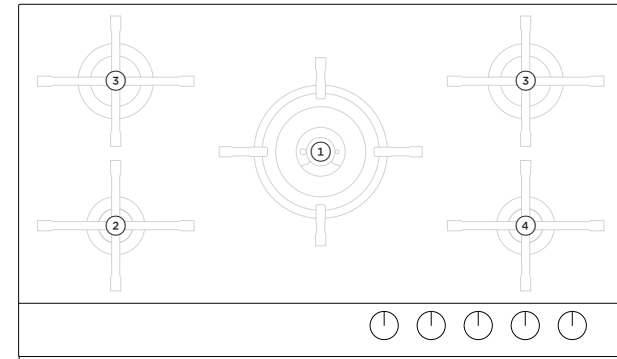

BURNER	GAS TYPE	JET SIZE (MM)	NOMINAL RATING (MJ/H)
① Dual wok	NG (1.00kPa)*	1.30	18.00
		0.70	
	ULPG (2.75kPa)*	0.76	18.00
		0.50	
② Rapid	NG (1.00kPa)*	1.55	11.50
	ULPG (2.75kPa)*	0.94	11.50
③ Semi-rapid	NG (1.00kPa)*	1.30	8.30
	ULPG (2.75kPa)*	0.76	7.50
④ Auxiliary	NG (1.00kPa)*	0.85	3.60
	ULPG (2.75kPa)*	0.55	3.60

*Nominal pressure with at least one large burner on high

PROUD INSTALLATION

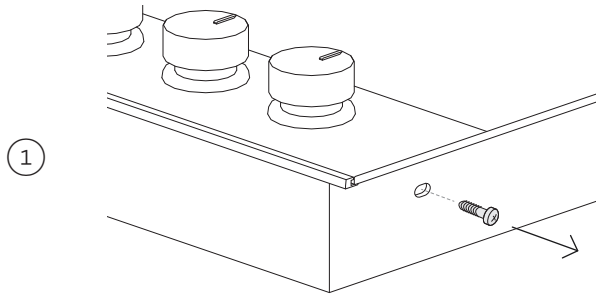

1 Remove the transit screws from both sides of the cooktop.

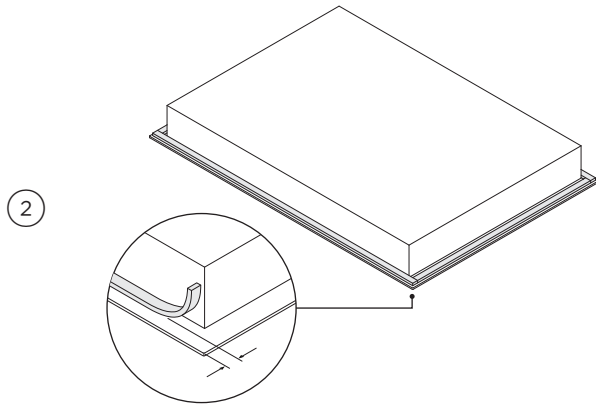

2 Apply adhesive foam seal around the glass overhang, 5mm in from the edge of the glass.

Ensure the adhesive side is facing down to form a continuous seal around the cooktop.

Trim any excess seal using a sharp knife taking care not to damage the cooktop or surface.

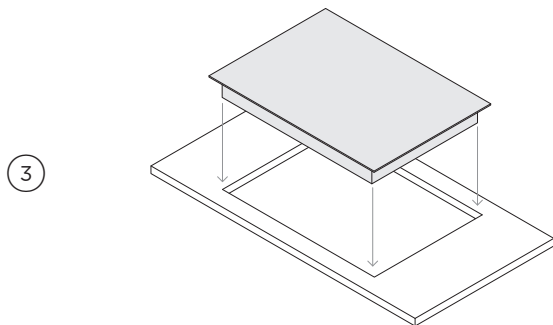

3 Gently lower the cooktop into the cutout ensuring you have access below the countertop to fit and secure the brackets.

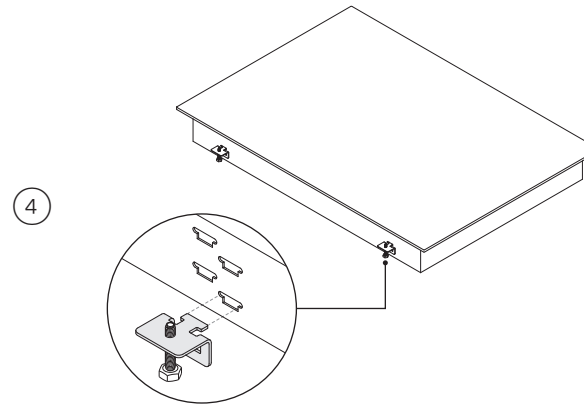

4 Locate the side brackets* to the appropriate slots on the cooktop chassis. The correct slot height is determined by the thickness of your countertop.

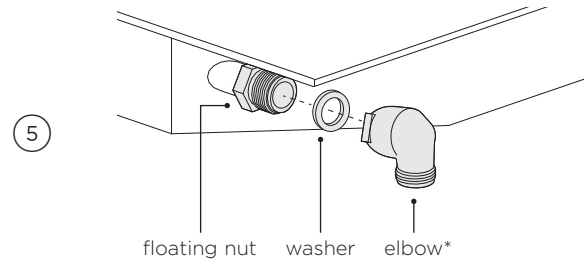

5 Fit the elbow and washer to the floating nut before carefully turning the cooktop over and placing onto a protected surface.

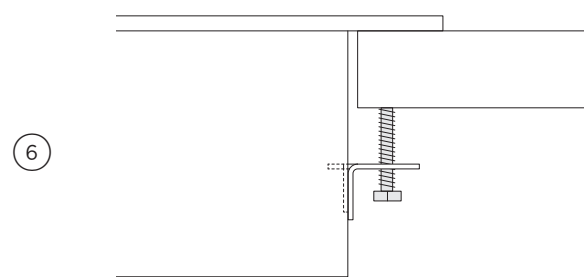

6 Tighten all screws to secure the cooktop to the countertop. Ensure cooktop is level.

*(1/2" BSP external thread)

*The number of brackets varies based on your cooktop model

FLUSH INSTALLATION

1

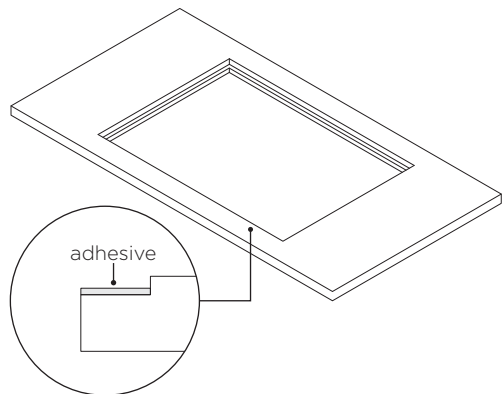

Prepare the countertop for flush installation. Use a router to cutout the edges of the countertop to specified depth (5mm). Attach an adhesive tape along the edges of the routed recess.

2

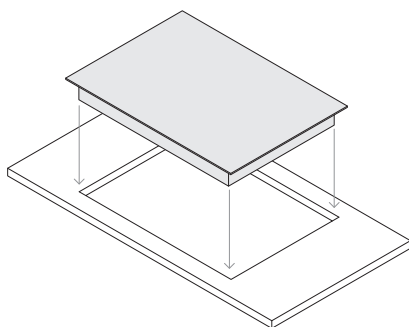

Gently lower the cooktop into the cutout ensuring you have access below the countertop to fit and secure the brackets.

3

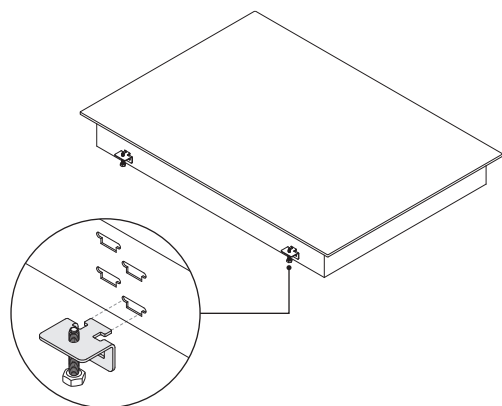

Locate the side brackets* to the appropriate slots on the cooktop chassis. The correct slot height is determined by the thickness of your countertop.

*The number of brackets varies based on your cooktop model

4

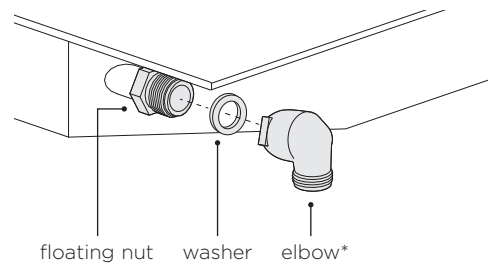

floating nut washer elbow*

Fit the elbow and washer to the floating nut before carefully turning the cooktop over and placing onto a protected surface.

5

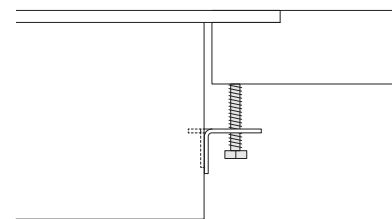

Tighten all screws to secure the cooktop to the countertop. Ensure cooktop is level.

6

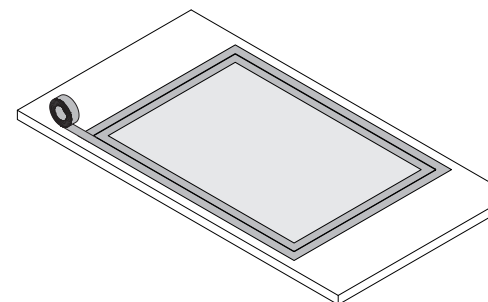

Mask off the area to be siliconed ensuring both the cooktop and countertop are protected.

7

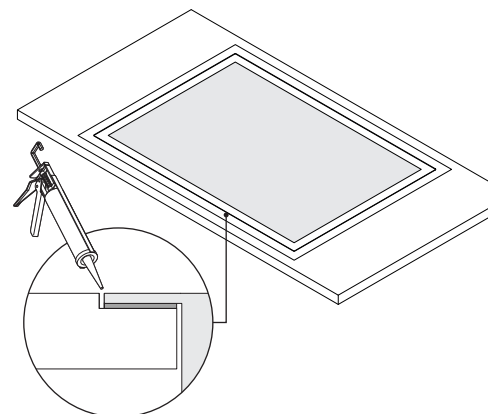

Apply silicone in the gap between countertop and cooktop. Wipe off any excess silicone.

NATURAL GAS MODELS

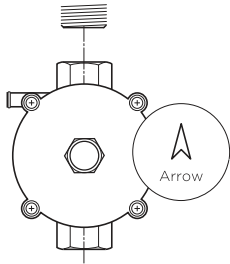

Ensure the supplied regulator is fitted.
Adjust to obtain a test point pressure of 1kPa with all burners operating at the highest setting.

LPG MODELS



Ensure the supplied test point adapter is fitted.
Adjust to obtain a test point pressure of 1kPa with all burners operating at the highest setting.

ALL MODELS

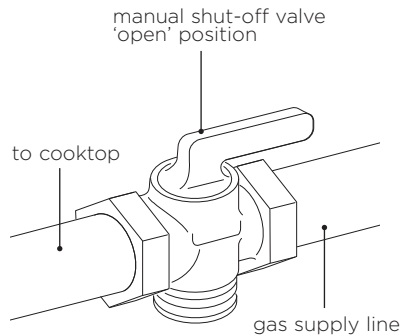

- Ensure the connection point will be accessible with the installed cooktop.
- Use an isolating valve close to the cooktop.

If connecting the gas with a flexible hose:

- Ensure the hose is long enough to allow for removal of cooktop for servicing.
- Ensure the connected is located as shown in 'Clearance dimensions'.
- The hose assembly must be AS/NZ 1869 Class B or D certified, with an Rp 1/2" (ISO7-1) female thread connection.
- The hose assembly must be longer than 1.2m in length with minimum internal diameter of 10mm and comply with relevant AS 5601/NZS 5261 requirements.
- Ensure the hose is not kinked, and not subjected to abrasion or permanently deformed.
- Ensure the hose is not near or in contact with any hot surfaces (eg base of metal hotplate, flue, or chassis of underbench oven, etc).

LEAK TESTING

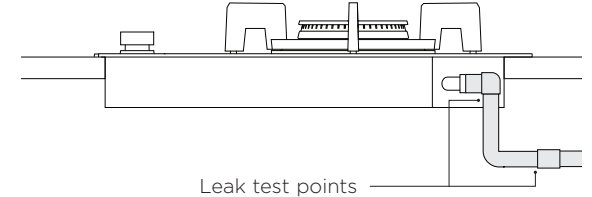
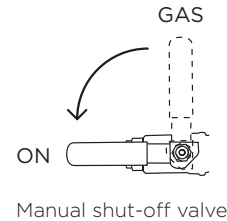

- Ensure all dials are set to **OFF** before connecting cooktop to gas supply.
- After final gas connection is made, turn gas supply on and test all connections in gas supply piping for gas leaks with a soapy water solution.
- In order to avoid property damage or serious personal injury, never use a match or open flame. If a leak is present, tighten joint or unscrew, apply more joint compound, tighten again and retest connection for leak.

ELECTRICAL CONNECTION

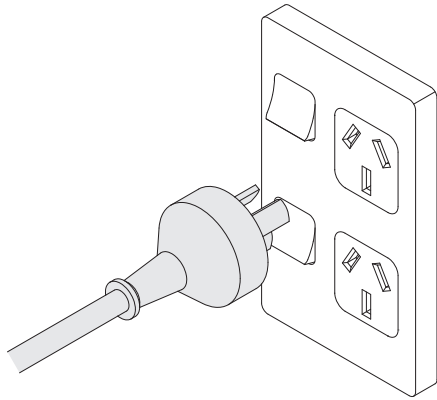

Connect the cooktop to the power supply and attach the duplicate data label to an accessible location.

COOKTOP BURNERS

ATTACH PAN SUPPORTS

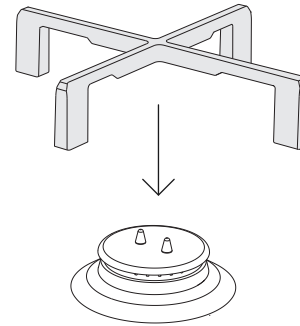

Securely locate all pan supports ensuring they are installed in the correct orientation and do not rock.

TEST BURNERS

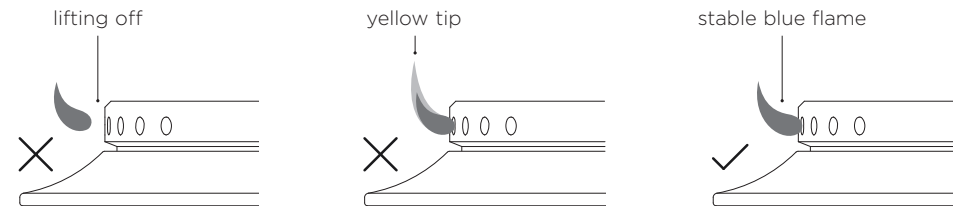

- To check that the ignition system operates correctly, light each burner by itself, then all burners in combination.
- Check for a well-defined blue flame without any yellow tipping.
- If any abnormality is evident, check that the components of the burner assembly are located properly.
- No air shutter adjustment is possible on the cooktop. Correct operation is achieved with factory installed settings for the correct gas type.
- When installing the burner port ring, align the two locating pins in the bottom side of the port ring with the locating notch and centre holes on the top side of the simmer ring, and make sure these are properly engaged.
- Incorrect installation may produce a potentially dangerous flame and result in poor burner performance.
- If proper operation cannot be obtained, contact Customer Care or your nearest Fisher & Paykel Authorized Service Centre.
- The cooktop must not be used until proper operation has been achieved.

INSTALLER CHECKLIST

TO BE COMPLETED BY THE INSTALLER

GENERAL

- Specified clearance maintained.
- Unit is level – front to back and side to side.
- All packaging materials have been removed.
- Dials turn correctly and freely.
- Burners light satisfactorily, both individually and with other burners operating.
- There is a constant flow of cool air from the cabinetry to the base of the cooktop.
- Cooktop is securely clamped.
- Basic operation has been demonstrated to the customer.

GAS

- Manual gas shut-off valve installed in an accessible location.
- Unit tested and free of gas leaks.

ELECTRICAL

- Receptacle with correctly rated over-current protection is provided for service cord connection.
- Adequate ground connection.
- Power supply cable is not touching the cooktop and accessible.

Complete and keep for safe reference:

Model _____

Serial No. _____

Purchase Date _____

Purchaser _____

Dealer Address _____

Installer's Name _____

Installer's Signature _____

Installation Company _____

Installation Date _____

FISHERPAYKEL.COM

© Fisher & Paykel Appliances 2020. All rights reserved.

The models shown in this guide may not be available in all markets
and are subject to change at any time.

The product specifications in this guide apply to the specific products and
models described at the date of issue. Under our policy of continuous product
improvement, these specifications may change at any time.

For current details about model and specification availability in your country,
please go to our website or contact your local Fisher & Paykel dealer.

592233B 05.20