

# ACM804BA

60CM Induction Cooktop

Whirlpool®



## FEATURES & BENEFITS



### POWER MANAGEMENT

Consumers can select between 4 different levels of maximum power absorption depending on the available power in the house.



### ELECTRONIC SLIDER CONTROL

Control all cooking zones just by sliding your finger.



### RESIDUAL HEAT INDICATORS

As long as the element is hot a light will continue to glow. This safety feature will lessen the chance of accidentally burning yourself.

## TECHNICAL SPECIFICATIONS

MAIN COLOUR FINISH	Glass
PRODUCT DIMENSIONS	W 580mm x H 52mm x D 510mm
COOKING ZONES	4
BOOSTER ZONES	4
FUNCTIONS	Power Management Auto Pot Recognition Residual Heat Indicator Acoustic Signal Timer Programmable Timer
CONTROLS	Electronic Slider
POWER REQUIREMENTS	7.2kW 240VAC 50Hz
POWER LEVELS	18 + Booster
CURRENT REQUIREMENTS	31.3amps
INSTALLATION	Built-In
NET WEIGHT	12.5kg
WARRANTY	2 Years- parts and labour
COUNTRY OF ORIGIN	Italy

## ZONE SPECIFICATIONS

FRONT LEFT HAND SIDE SIZE (mm)	Min 10 - Max 14.5
FRONT RIGHT HAND SIDE SIZE (mm)	Min 15 - Max 21
REAR LEFT HAND SIDE SIZE (mm)	Min 15 - Max 21
REAR RIGHT HAND SIDE SIZE (mm)	Min 10 - 14.5

DISTRIBUTED BY ARISIT PTY LTD

40-50 Mark Anthony Drive,  
Dandenong South VIC 3175

Ph: 1300 762 219

Fax: 03 9768 0838

Website: [www.arisit.com](http://www.arisit.com)



# ACM804BA

## 60CM Induction Cooktop

### CUT OUT DIMENSIONS

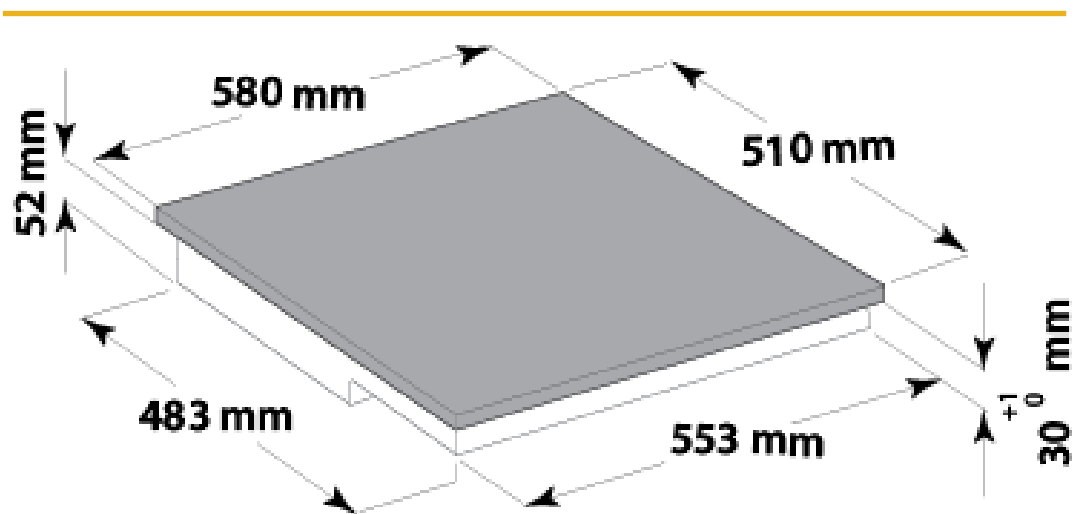

### VENTILATION REQUIREMENTS

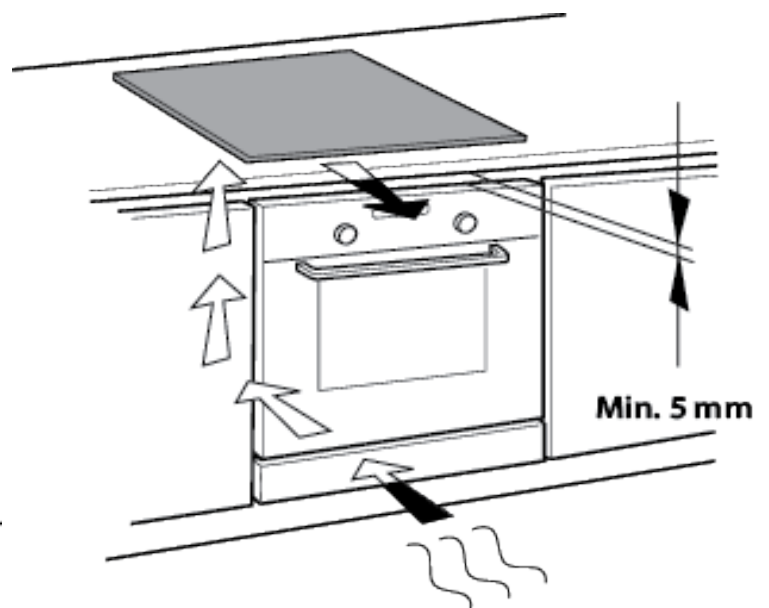
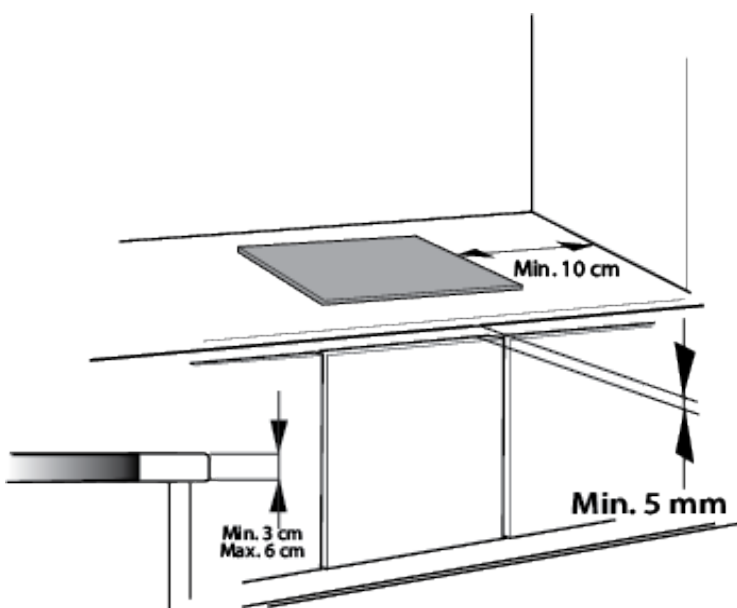

DISTRIBUTED BY ARISIT PTY LTD

40-50 Mark Anthony Drive,  
Dandenong South VIC 3175

Ph: 1300 762 219

Fax: 03 9768 0838

Website: [www.arisit.com](http://www.arisit.com)

